

MG2-A

Surface-mounted fire resistant collars.



CE
0749











Table of content

Declaration of performance	3
Product presentation MG2-A	4
Range and dimensions MG2-A	4
Storage and handling	5
Installation	5
Installation in rigid wall and floor	6
Installation in flexible wall (metal stud gypsum plasterboard wall)	8
Installation in flexible and rigid wall, sealing with rigid rock wool boards with coating	9
Weights	11
Approvals and certificates	11

Explanation of the abbreviations and pictograms

Dn = nominal diameter
E = integrity

I = thermal insulation
GKB (type A) / GKF (type F): "GKB" stands for standard plasterboards (type A according to EN 520) while "GKF" plasterboards offer a higher fire resistance for a similar plate thickness (type F according to EN 520)

	fast installation		water- and frost-resistant
	suitable for PE-HD pipes according to EN 1519-1, EN 12666-1 or EN 12201-2 and for ABS pipes according to EN 1455-1		suitable for PVC-U pipes according to EN 1329-1, EN 1453-1 or EN 1452-1 and for PVC-C pipes according to EN 1566-1
	suitable for surface-mount		minimal distance allowed
	oblique penetration allowed		sealing with fire resistant stone wool boards allowed, also for asymmetric opening

DECLARATION OF PERFORMANCE

CE_DoP_Rf-t_M2_EN = C-03/2020

1. Unique identification code of the product-type:	MG2-A
2. Intended use/es:	Sealing flammable pipes in penetrations through fire compartment walls and floors.
3. Manufacturer:	Rf-Technologies NV, Lange Ambachtstraat 40, B-9860 Oosterzele
4. System/s of AVCP:	System 1
5. Harmonised standard / European Assessment Document; notified body / European Technical Assessment, Technical Assessment Body, notified body; certificate of constancy of performance:	EAD 350454-00-1104, ETA 16/0041; UBAtc asbl; BCCA with identification number 0749; BCCA-0749-CPR-BC1-262-464-026-2.01-2517
6. Declared performance according to EAD 350454-00-1104	(fire resistance according to EN 1366-3, classification according to EN 13501-2)

Essential characteristics							Performance							
Wall type	Wall	Sealing	Type of pipe	Material pipe	Pipe diameter (mm)	Pipe wall thickness (mm)	Classification							
Rigid wall	Aerated concrete ≥ 100 mm	Not applicable	standard	PVC	32-75	1,8-8,4	EI 120 U/C, C/C							
					80-110	2,2-8,2	EI 120 U/C, C/C							
					125-160	3,2-11,9	EI 120 U/C, C/C							
					PE, ABS	32-75	3,0-6,8	EI 120 U/C, C/C						
						80-110	3,4-10,0	EI 120 U/C, C/C						
						125-160	5,0-14,6	EI 120 U/C, C/C						
				Geberit Silent db20	32-75	3,6	EI 120 U/C, C/C							
					80-110	6,0	EI 120 U/C, C/C							
					125-160	7,0	EI 120 U/C, C/C							
				zero distance (<100 mm)	PVC	32-160	see above	EI 120 U/C, C/C						
					PE, ABS	32-160	see above	EI 120 U/C, C/C						
				oblique crossing ≤ 30°	PVC	32-63	1,9-4,7	EI 120 U/C, C/C						
			75			1,8-8,4	EI 120 U/C, C/C							
			110			2,2-8,2	EI 120 U/C, C/C							
			PE, ABS			32-63	3,0-5,8	EI 120 U/C, C/C						
						75	3,0-6,8	EI 120 U/C, C/C						
						90	3,0-8,2	EI 120 U/C, C/C						
			110		3,4-10	EI 120 U/C, C/C								
			Rigid floor		Aerated concrete ≥ 150 mm	Not applicable	standard	PVC	32-75	1,8-8,4	EI 180 U/C, C/C			
									80-110	2,2-8,2	EI 180 U/C, C/C			
				125-160					3,2-7,7	EI 180 U/C, C/C				
				125-160					3,2-11,9	EI 90 U/C, C/C				
				PE, ABS					32-75	3,0-6,8	EI 180 U/C, C/C			
80-110	3,4	EI 180 U/C, C/C												
80-110	3,4-10,0	EI 120 U/C, C/C												
125-160	5,0	EI 180 U/C, C/C												
	5,0-14,6	EI 120 U/C, C/C												
	7,0	EI 90 U/C, C/C												
zero distance (<100 mm)	PVC	32-110		see above				EI 180 U/C, C/C						
	PVC	75		1,8-8,4				EI 120 U/C, C/C						
oblique crossing ≤ 30°	PVC	110		2,2-8,2			EI 120 U/C, C/C							
		PE, ABS		75			3,0-6,8	EI 120 U/C, C/C						
	110	3,4-10		EI 120 U/C, C/C										
Flexible wall	Metal studs gypsum plasterboard Type F (EN 520) ≥ 100 mm	Not applicable		standard			PVC	32-75	1,8-8,4	EI 120 U/C, C/C				
								80-110	2,2-8,2	EI 120 U/C, C/C				
								125-160	3,2-11,9	EI 120 U/C, C/C				
								PE, ABS	32-75	3,0-6,8	EI 120			
									80-110	3,4-10,0	EI 120			
									125-160	5,0-14,6	EI 120 U/C, C/C			
							Flexible wall / rigid wall	Metal studs gypsum plasterboard Type F (EN 520)/ Aerated concrete ≥ 100 mm	Stone wool + coating ≥ 140 kg/m³	standard	PVC	32-75	3,0	EI 120 U/C, C/C
												80-110	3,2	EI 120 U/C, C/C
			125-160		3,2	EI 120 U/C, C/C								
			PE, ABS		32-75	3,0					EI 120 U/C, C/C			
					80-110	4,2					EI 120 U/C, C/C			
					125-160	6,2					EI 120 U/C, C/C			

Harmonised standard
EAD 350454-00-1104

1 Type of installation: surface-mounted, U/C, C/C



Reaction to fire	class E (EN 13501-1)
Durability and ease of maintenance	Y2

The performance of the product identified above is in conformity with the set of declared performance/s. This declaration of performance is issued, in accordance with Regulation (EU) No 305/2011, under the sole responsibility of the manufacturer identified above.

Signed for and on behalf of the manufacturer by:
Mathieu Steenland, Technical Manager

Oosterzele, 03/2020



Product presentation MG2-A

Product presentation MG2-A

Wide range of fire resistant collars that can easily be mounted on the wall. They have been tested according to EN1366-3 and are fire resistant up to 180 minutes in rigid walls and floors and in flexible walls. The fire resistant collar MG2-A is mounted on the surface of walls and floor slabs around plastic pipes (PVC, HDPE, ABS). In case of a vertical wall, a collar is installed on both sides of the wall. In case of a floor, a single MG2-A is enough on the lower side of the floor.

When combustible pipes burn away, openings appear in the floor or walls through which fire can spread. Fire resistant collars prevent propagation of fire by expanding through heat, thus closing off the openings and making them fire resistant.

- ✓ water- and frost-resistant
- ✓ fast installation
- ✓ no specific tools, no sealing required
- ✓ minimal collar height for a superior flexibility
- ✓ CE marking according to EAD 350454-00-1104
- ✓ installation U/C, C/C (uncapped-capped / capped-capped).
minimal distance allowed
- oblique penetration allowed
- extensive field of application
- maintenance-free
- sealing with fire resistant stone wool boards allowed, also for asymmetric opening
- suitable for surface-mount
- suitable for PVC-U pipes according to EN 1329-1, EN 1453-1 or EN 1452-1 and for PVC-C pipes according to EN 1566-1
- suitable for PE-HD pipes according to EN 1519-1, EN 12666-1 or EN 12201-2 and for ABS pipes according to EN 1455-1



1. steel housing
2. intumescent strips
3. wall anchors

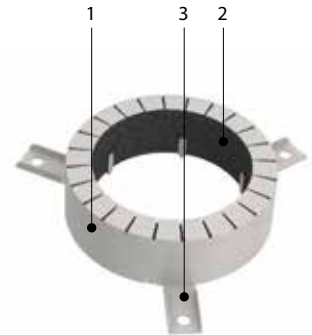

Range and dimensions MG2-A

number of fixation points: 2 ($\varnothing D_n$ 32-75) / 3 ($\varnothing D_n$ 80-110) / 4 ($\varnothing D_n$ 125-160)

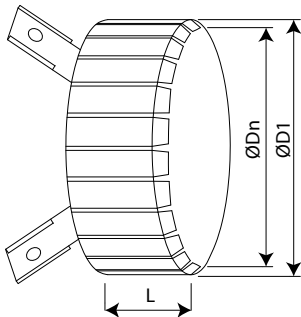

$\varnothing D_n$ (mm)	32	40	50	56	63	75	80	90	100	110	125	140	160
D1	48	58	68	74	80	93	110	125	132	140	173	187	206
L	40	40	40	40	40	40	40	40	40	40	40	40	40

D1 = outside diameter of the collar

Dn = inside diameter of the collar, corresponding to the outside diameter of the pipe

Wall: 2 x MG2-A

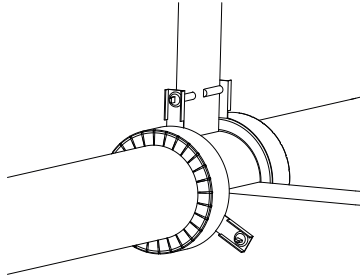

Wall: 2 x MG2-A

Floor: 1 x MG2-A

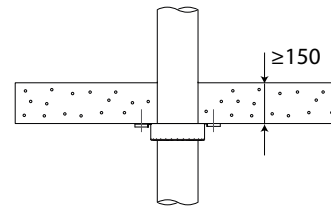

Floor: 1 x MG2-A

Storage and handling

As this product is a safety element, it should be stored and handled with care.

It is recommended:

- to unload in a dry area
- to keep in a cool, dry area, protected from heat
- to transport the product in a closed vehicle

Installation

General points

- The installation must comply with the installation manual and the classification report.
- The pipe must be supported in order to guarantee the well-functioning of the sealing during a fire. Supports and fastenings should be realised according to the rules of good craftsmanship.

Installation in rigid wall and floor

The product was tested and approved in: see the classification overview in the Declaration of Performance. Mounting is authorised in supporting constructions with a thickness and/or density equal or superior to the supporting construction used during the test, as described in EN 1366-3.

1

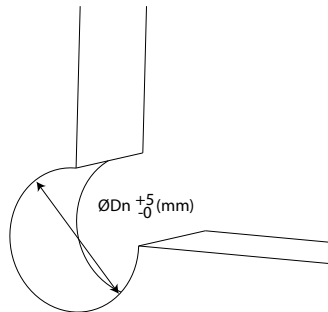

1. Provide an installation opening of $\varnothing D_n$ mm.

2

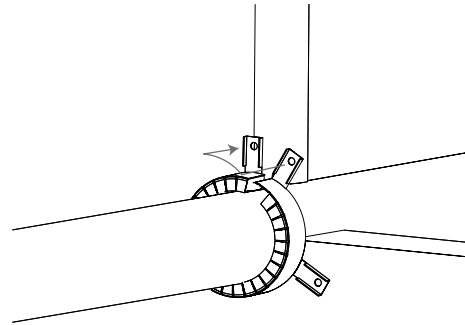

2. Keep one end of the collar in place with your left hand whilst bending the collar around the pipe with your right hand. Click the wall anchors into each other, right anchor on top of the left one.

3

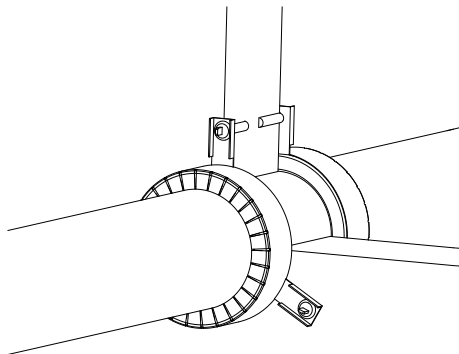

3. Reinforced concrete: place expander bolts in the pre-drilled holes $\varnothing 6$ mm and fasten them. Aerated concrete: fix with universal M6 screws.

Mount the second collar on the other side of the wall in the same way.

Apply the label nearby the collar.

4

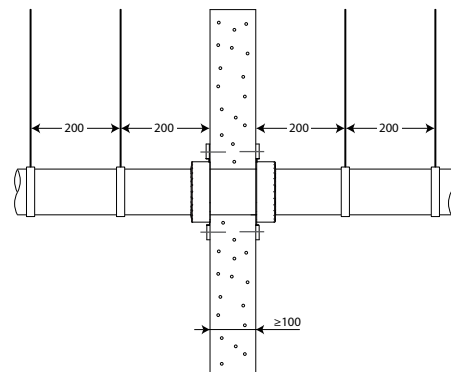

5

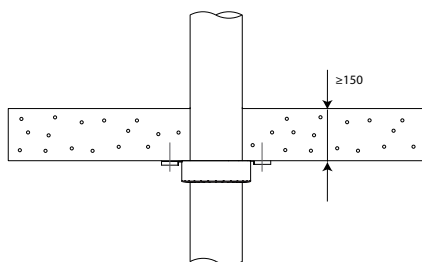

5. One collar on the bottom side of the floor is sufficient for floor penetrations.

6

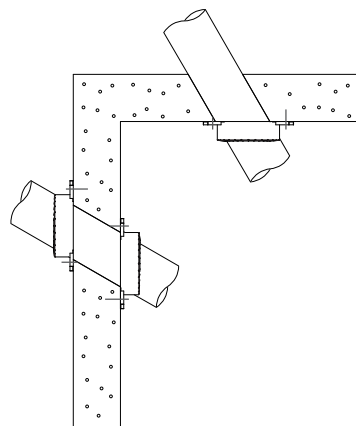

6. For oblique penetrations till 30°, choose the collar with dimensions as close as possible to the outside diameter of the pipe. See the classification report on www.rft.be for an overview of the classifications.

7

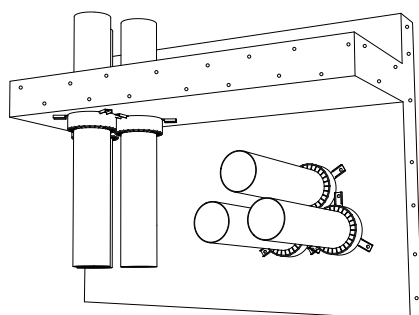

7. For zero distances: the collars can be placed against one another (< 100 mm). See declaration of performance for the correct classification.

Installation in flexible wall (metal stud gypsum plasterboard wall)

The product was tested and approved in: see the classification overview in the Declaration of Performance. Mounting is authorised in supporting constructions with a thickness and/or density equal or superior to the supporting construction used during the test, as described in EN 1366-3.

1

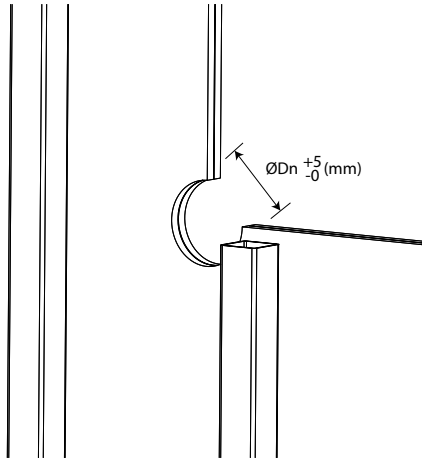

1. Fix two gypsum boards type F with a thickness of 12,5 mm to one side of the metal stud wall. Provide an installation opening of $\varnothing D_n$ mm.

2

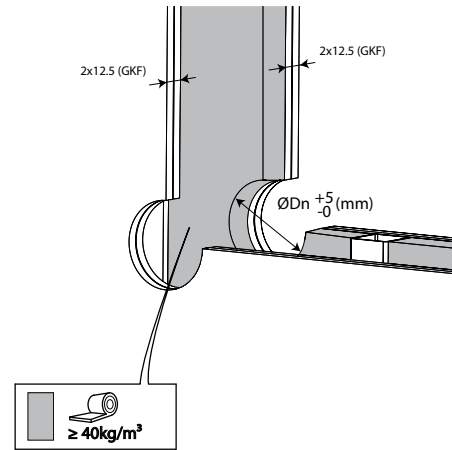

2. Insulate the wall and finish with two gypsum plasterboards type F.

3

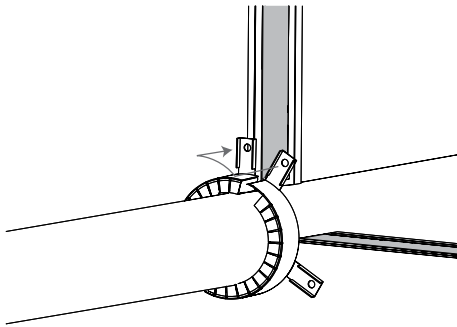

3. Place the plastic pipe. Keep one end of the collar in place with your left hand whilst bending the collar around the pipe with your right hand. Click the wall anchors into each other, right anchor on top of the left one.

4

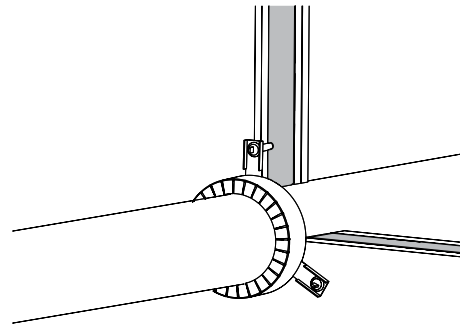

4. The MG2-A may be fixed by universal screws (M6) or by threaded rods, washers and bolts.

5

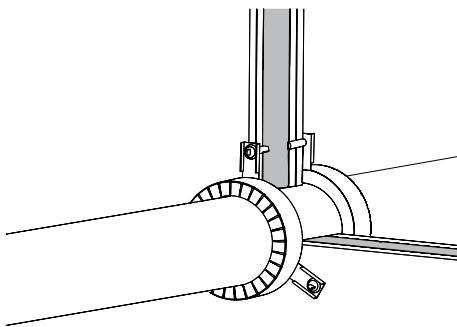

5. Mount the second collar on the other side of the wall in the same way. Apply the label nearby the collar.

6

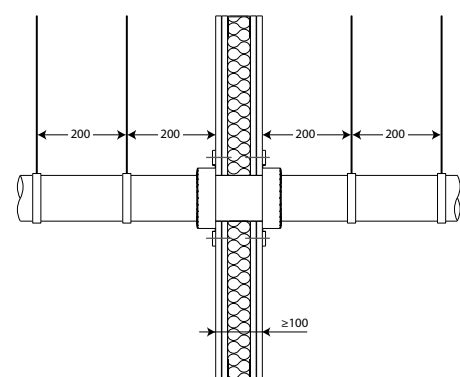

Installation in flexible and rigid wall, sealing with rigid rock wool boards with coating

The product was tested and approved in: see the classification overview in the Declaration of Performance. Mounting is authorised in supporting constructions with a thickness and/or density equal or superior to the supporting construction used during the test, as described in EN 1366-3.

1

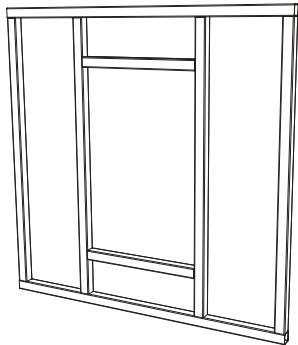

1. Provide an installation opening of maximally 1000 x 600 mm.

2

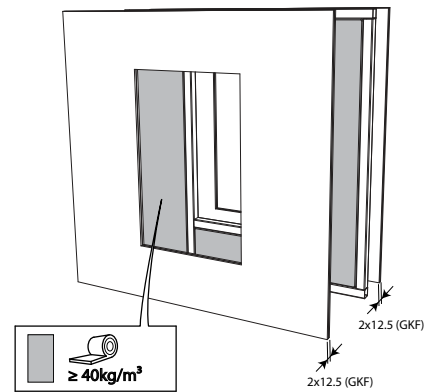

2. Fix two gypsum plasterboards type F of 12,5 mm thickness to each side of the metal studs and insulate the wall with 40 mm mineral wool, 40 kg/m³.

3

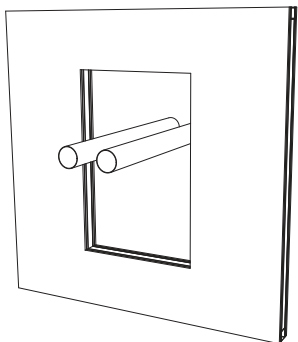

3. Place the plastic pipe(s). The distances between the pipes and the edges of the seal are min. 100 mm.

4

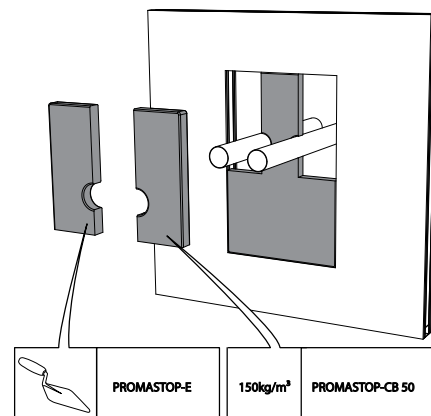

4. Fix a stone wool board of min. 50 mm thickness with fire resistant coating on one side (type PROMASTOP-CB 50) around the fire collars. Use a saw or knife to dimension the stone wool boards. Apply endothermic coating (type PROMASTOP-E) on the lateral sides, as well as on the joints.

5

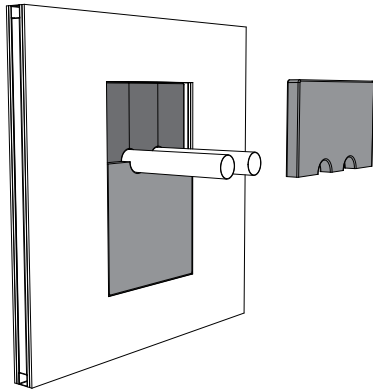

5. Put the second stone wool board of min. 50mm thickness around the pipes. Avoid the joints from coinciding. Apply endothermic coating (type PROMASTOP-E) on the lateral sides, as well as on the joints.

6

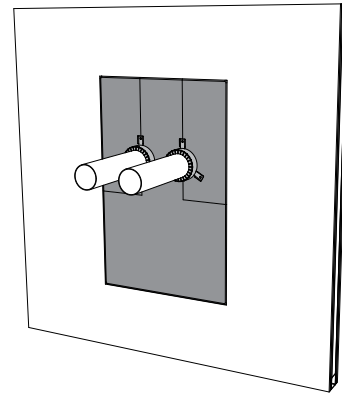

6. Place the surface-mounted collars at each side around the pipes and fix with threaded rods, washers and bolts (M6). Apply the label nearby the collar.

7

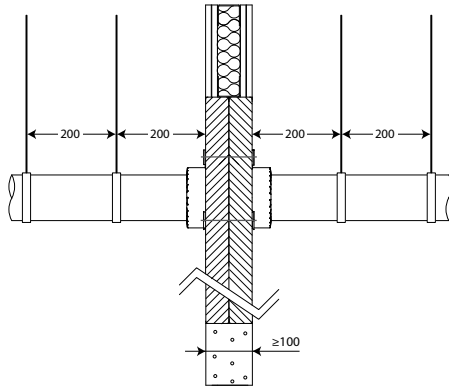

Weights

MG2-A

$\varnothing D_n$ [mm]	32	40	50	56	63	75	80	90	100	110	125	140	160
kg	0,1	0,1	0,1	0,2	0,2	0,2	0,2	0,3	0,3	0,3	0,4	0,5	0,6

Approvals and certificates

All our products are submitted to a number of tests by official test institutes. Reports of these tests form the basis for the approvals of our products.



BCCA-0749-CPR-BC1-262-464-026-2.01-2517